

MIL 81000

Three Way Combining and Diverting Control Valves



Authorised Dealer;
PUSHKARNA SALES PVT LTD.
4772. Hauz Qazi. Delhi-110006.
Phones; 011-43675881/9818453355.
Email; sales@pushkarnasales.com
Site; www.pushkarnasales.com





Table of Contents

Introduction	01
Features	02
Typical Applications	02
Technical Information	03 - 06
<ul style="list-style-type: none"> • Model Decodification • Standard Size / Ratings / End Connections • General Data • Seat Leakage Class / Temperature Range • Flow Coefficients (Rated Cv) • Actuator Selection 	
Construction	07 - 08
Dimensions and Weights	09



Introduction

MIL 81000 series valve is designed specifically for the control of flow and temperature where mixing or diverting service is required in process control industries. This is accomplished with the help of its three way body construction. Combining body construction has two separate inlets and one outlet which involve mixing of two streams into single one. Diverting body construction has a single inlet and two separate outlets where fluid from single stream gets divided into two proportionately.



Features

Top and Bottom Entry Construction

This helps in easy access for inline maintenance and repair as required. If the fluid is carrying sediments, bottom flange can be removed and valve body housing can be cleared of debris.

High Capacity with Low Recovery

Flow capacity is at top levels for three way valves and this is attained with very little pressure recovery by its high critical flow factors which minimize possibility of cavitation in liquid services.

Plug Stability

Valves are designed to be installed with flow tending to open both ports which provides inherent plug stability. Top and skirt guiding also ensures increased stability during plug travel.

High Performance Materials

Material of construction has been selected for high performance and long life.

Durability

Rugged construction and smooth operation guarantee long maintenance-free service life.

Reduced Inventory Control

Reduced inventory due to the common parts used in combining and diverting construction and having compatibility with other MIL double ported valve series.

Typical Applications

The high flow and low head loss characteristics make the 81000 series ideal for domestic water, radiant applications, and installations with large variations in flow rate and supply conditions, and installations requiring tightly controlled water temperature. This is also used in power plants as main trip valve for combining services.





Technical Information

Model Decodification

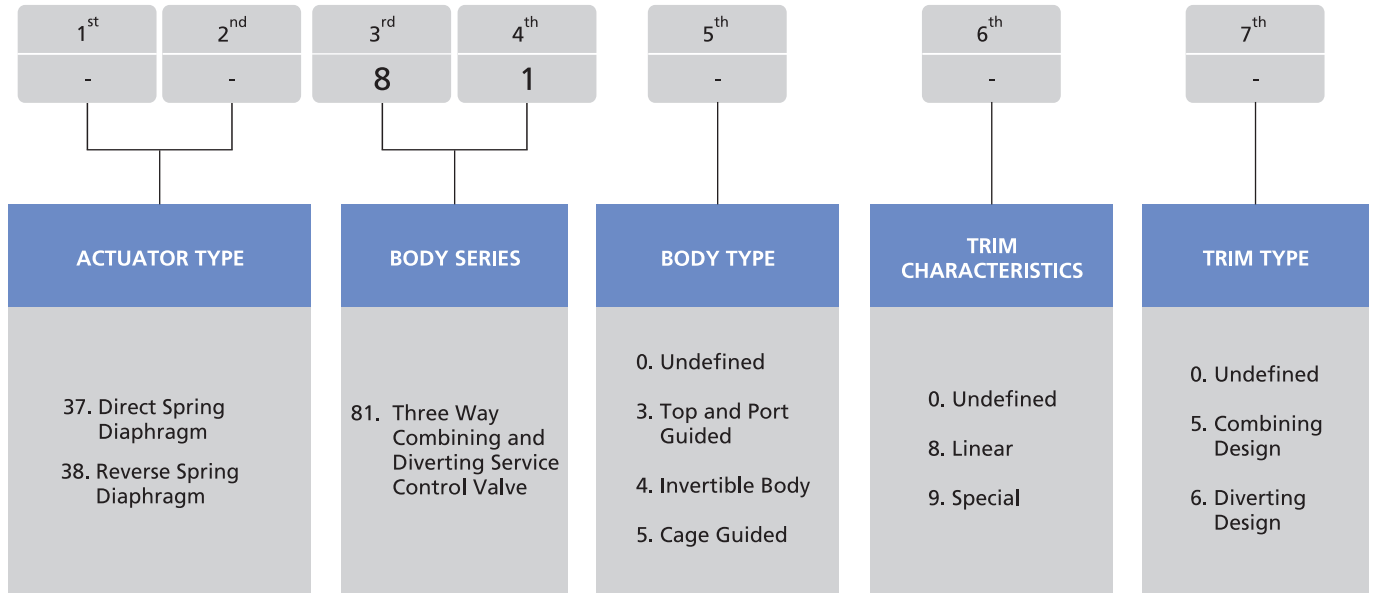

Standard sizes / Ratings / End connection ⁽¹⁾

VALVE SIZE (inch)	RATING (ASME Class)					
	150#	300#	600#	900#	1500#	2500#
1	*	*	*		⁽²⁾ *	
1.5	*	*	*			
2	*	*	*			
3	*	*	*			⁽²⁾ *
4	*	*	*			
6	*	*				
8	*	*	⁽²⁾ *	⁽²⁾ *	⁽²⁾ *	
10	*	*	⁽²⁾ *			
12	⁽²⁾ *	⁽²⁾ *		⁽³⁾ *		

⁽¹⁾ 81000 Series valves are available only with flanged ends. For weld end, please consult MIL

* Available

⁽²⁾ For diverting service only, for other ranges, consult MIL

⁽³⁾ Available only for combining service



General Data

BODY	
Type	: Three-way combining or diverting
Option	: Invertible body, combining and diverting action in the same body Cage guided, pressure balanced
Flow direction	: Flow-to-open (both ports)
BONNET	
Type	: Bolted
Temperature Range	: -30°C to 454°C

GLAND SEAL	
Type	: Adjustable double sealed packing box with PTFE or Graphite moulded split rings
Temperature range	: ≤ 180°C PTFE > 180°C Graphite
TRIM	
Plug Type	: Combining Diverting
Guiding	: Top and Port guiding
Rangeability	: 50 : 1
Characteristics	: Linear, full capacity (reduced capacity on request)

Seat Leakage Class / Temperature Range

VALVE SIZE (inch)	RATING (ASME Class)	TEMPERATURE RANGE (°C)		SEAT LEAKAGE CLASS (FCI 70.2)
		MIN.	MAX.	
1 - 12	150# - 1500#	-30	454	IV
1 - 2	150# - 600#	-30	232	VI

Flow Coefficients (Rated Cv)

(81386)

VALVE SIZE (inch)	RATING (ASME Class)	STROKE (inch)	ORIFICE (inch)	RATED Cv
1	150#-600#	0.75	1.5	6,9
	1500#	0.75	1.5	6
1.5	150#-600#	0.75	1.5	21
2	150#-600#	1	2	36
3	150#-600#	1.5	2.63	54, 75
	2500#	1.5	2.63	60
4	150#-600#	1.5	3.5	124
6	150#-300#	2	5.25	270
8	150#-600#	2.5	7	400, 480
	900#-1500#	2.5	7	400
10	150#-300#	2.5	8.75	750
	600#	2.5	8.75	400,800,750
12	150#-300#	3.5	10.5	1200

(81385)

VALVE SIZE (inch)	RATING (ASME Class)	STROKE (inch)	ORIFICE (inch)	RATED Cv
1	150#-600#	0.5	1	6, 9
1.5	150#-600#	0.75	1.5	21
2	150#-600#	1	2	36
3	150#-600#	1.5	2.63	54, 75
4	150#-600#	1.5	3.5	124
6	150#-300#	2	5.25	270
8	150#-300#	2.5	7	400, 480
10	150#-300#	2.5	8.75	750
12	900#	3.5	10.5	1400



Actuator Selection (Spring Diaphragm Actuator)

Rating : 150# - 600# (ASME Class)
Seat Leakage Class IV (FCI 70.2)

VALVE SIZE (inch)	STROKE (inch)	Cv	ACTUATOR SIZE	SPRING RANGE (psig)	SUPPLY PRESSURE (psig)	SHUT OFF PRESSURE 81385 (Kg/cm ² g)	SHUT OFF PRESSURE 81386 (Kg/cm ² g)
1	0.5*, 0.75**	9	11	3-15	25	4.5	4.5
				16-30, 11-30**	50	85	56
1.5	0.75	21	11	6-30	45	10.5	10.5
				11-30	50	27	27
2	1	36	13	3-15	25	2	2
				6-30	45	10	10
				16-31	55	35	35
			15	3-15	25	6	6
				6-30	45	18	18
				15-30	55	53	53
3	1.5	54,75	13	6-30	45	5	5
				12-31	50	14	14
			15	3-15	25	2.5	2.5
				6-30	45	9.5	9.5
			18	14-31	55	28	28
				3-15	25	6.5	6.5
4	1.5	124	13	12-30	50	38	38
				18-30	60	59	59
			15	6-30	45	2	2
				11-30	50	11	11
			18	14-31	55	15	15
				6-30	45	9	9
6	2	270	15	12-30	50	21	21
				18-30	60	33	33
			18	6-30	45	1.5	1.5
				10-31	50	4	4
			24	6-30	45	3.5	3.5
				12-30	50	9	9
8	2.5	400,480	18	17-30	55	13	13
				12-30	50	4.5	4.5
			24	15-30	55	6	6
				15-30	55	9	9
10	2.5	400,750,800	18	12-30	55	3	3
				15-30	60	4	4
			24	15-30	55	5.5	5.5

* 0.5", 16-30 for 81385

** 0.75", 11-30 for 81386

Actuator selection for higher rating valves, consult MIL



Air failure positions for 81385 / 81386

37 ACTUATORS (AIR TO CLOSE)				38 ACTUATORS (AIR TO OPEN)			
81385		81386		81385		81386	
U → C : Closed L → C : Open		C → L : Closed C → U : Open		L → C : Closed U → C : Open		C → U : Closed C → L : Open	
Air Failure Positions							

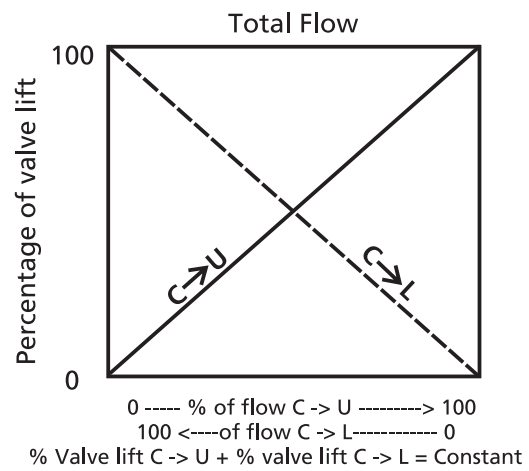
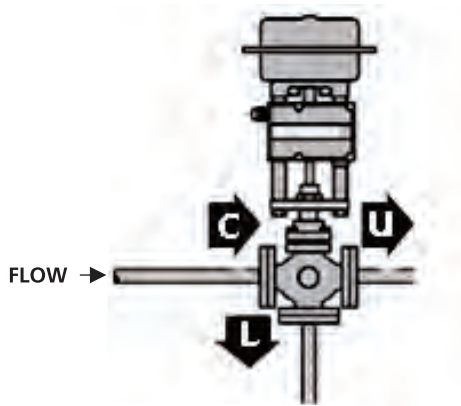

Typical Cv versus Travel Values

VALVE SIZE (inch)	PERCENT OF PLUG TRAVEL																					
	PLUG UP 0%		10%		20%		30%		40%		50%		60%		70%		80%		90%		PLUG DOWN 100%	
1	0	9	0.9	8.1	1.8	7.2	2.7	6.3	3.6	5.4	4.5	4.5	5.4	3.6	6.3	2.7	7.2	1.8	8.1	0.9	9	0
1.5	0	21	2.1	18.9	4.2	16.8	6.3	14.7	8.4	12.6	10.5	10.5	12.6	8.4	14.7	6.3	16.8	4.2	18.9	2.1	21	0
2	0	36	3.6	32.4	7.2	28.8	10.8	25.2	14.4	21.6	18.0	18.0	21.6	14.4	25.2	10.8	28.8	7.2	32.4	3.6	36	0
2.5	0	54	5.4	48.6	10.8	43.2	16.2	37.8	21.6	32.4	27	27	32.4	21.6	37.8	16.2	43.2	10.8	48.6	5.4	54	0
3	0	75	7.6	7.5	15	60	22.5	52.5	30	45	37.5	37.5	45	30	52.5	22.5	60	15	67.5	7.5	75	0
4	0	124	12.4	111.6	24.8	99.2	37.2	86.8	49.6	74.4	62	62	74.4	49.6	86.8	37.2	99.2	24.8	111.6	12.4	124	0
6	0	270	27	243	54	216	81	189	108	162	135	135	162	108	189	81	216	54	243	27	270	0
8	0	480	48	432	96	384	144	336	192	288	240	240	288	192	336	144	384	96	432	48	480	0
10	0	750	75	675	150	600	225	525	300	450	375	375	450	300	525	225	600	150	675	75	750	0

0% : Plug in up position, 100% : Plug in down position



Construction

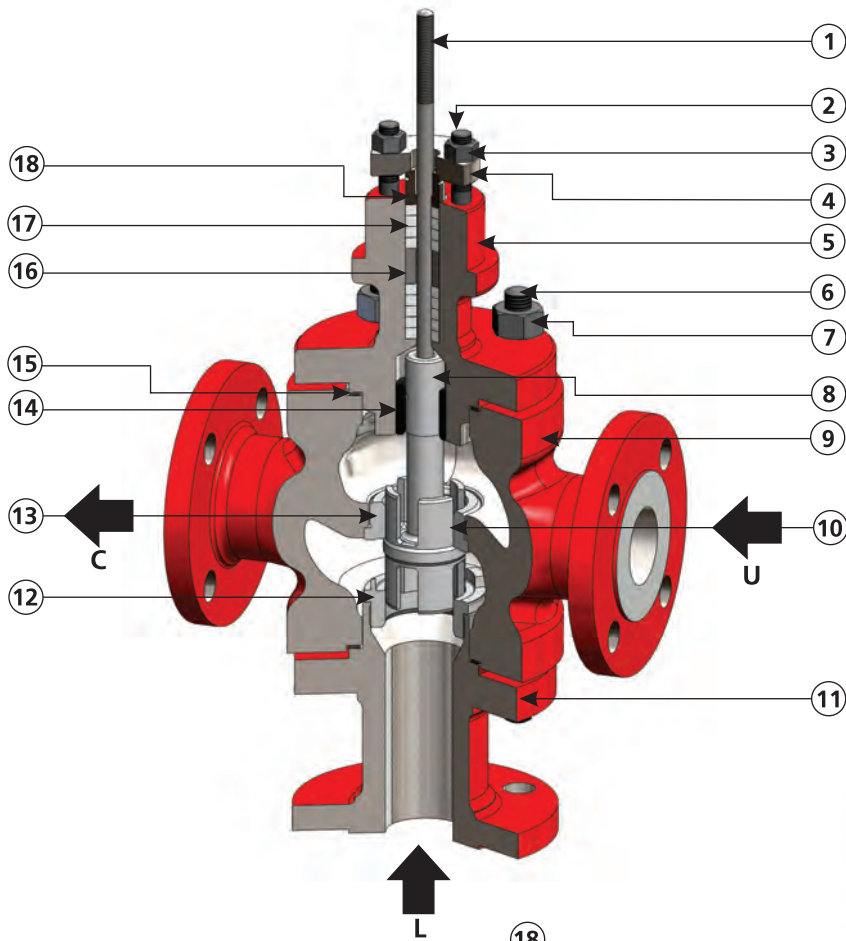

81385
Combining Valve

81386
Diverting Valve

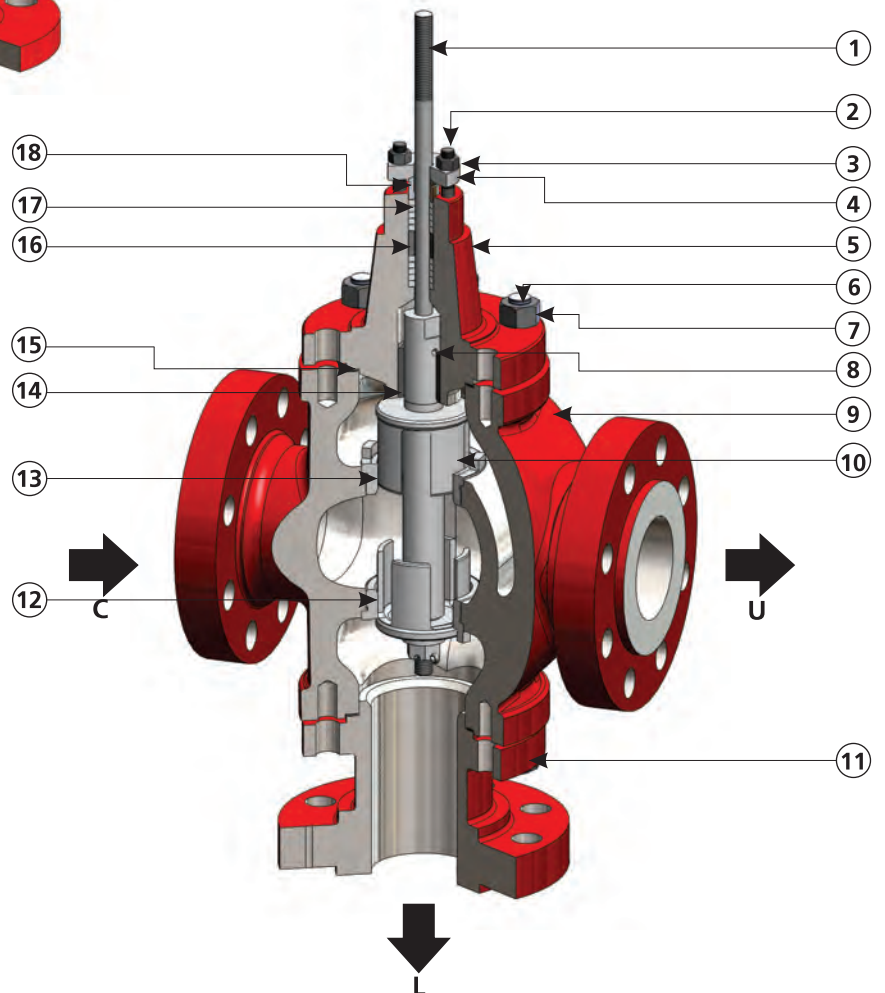



Material of Construction

DRAWING REF. NO.	PART NAME	STANDARD MATERIAL*
1	Plug Stem	316 SST
2	Packing Flange Stud	ASTM A 193 Gr. B8
3	Packing Flange Nut	ASTM A 194 Gr 8
4	Packing Flange	ASTM A 105
5 , 9	Bonnet, Body	Carbon Steel : ASTM A 216 Gr. WCC
		Stainless Steel : ASTM A 351 Gr CF8M
6	Body Stud	ASTM A 193 Gr B7
7	Body Nut	ASTM A 194 Gr 2H
8	Plug Pin	316 SST
10	Plug	316 SST
11	Bottom Flange	Carbon Steel : ASTM A 216 Gr. WCC
		Stainless Steel : ASTM A 351 Gr CF8M
12	Lower Seat Ring	316 SST
13	Upper Seat Ring	
14	Guide Bush	440 C SST Heat Treated / 316 SST Stellite
15	Body Gasket	316L SST + Graphite
16	Packing Spacer	304 SST
17	Packing	PTFE $\leq 180^{\circ}\text{C}$ / Graphite $> 180^{\circ}\text{C}$
18	Packing Follower	304 SST

*Material indicated above are for reference only. MIL reserves the right to supply alternate material due to constant product upgradation. Other specific material are available on request.



Dimensions and Weights

VALVE MODEL	VALVE SIZE (inch)	150# (ASME Class)				300# (ASME Class)				600# (ASME Class)			
		DIMENSIONS (mm)			UNPACKED WEIGHT (kg)	DIMENSIONS (mm)			UNPACKED WEIGHT (kg)	DIMENSIONS (mm)			UNPACKED WEIGHT (kg)
		A	B	H		A	B	H		A	B	H	
81385	1	185.5	140	130	23	198.5	140	130	23	211	140	130	32
	1.5	222.5	159	133.5	41	235	159	133.5	41	251	159	133.5	46
	2	254	169.5	152.5	57	267	169.5	152.5	57	286	169.5	152.5	64
	3	298.5	203	203.5	100	317.5	203	203.5	100	336	203	203.5	107
	4	352.5	229	213.5	136	368	229	213.5	136	393.5	257	213.5	150
	6	451	292	270.5	238	473	292	270.5	238	-	-	-	-
	8	543	336	320	351	568.5	336	320	351	-	-	-	-
	10	660.5	390.5	328	780	695.5	390.5	328	780	-	-	-	-
VALVE MODEL	VALVE SIZE (inch)	150# (ASME Class)				300# (ASME Class)				600# (ASME Class)			
		DIMENSIONS (mm)			UNPACKED WEIGHT (kg)	DIMENSIONS (mm)			UNPACKED WEIGHT (kg)	DIMENSIONS (mm)			UNPACKED WEIGHT (kg)
		A	B	H		A	B	H		A	B	H	
81386	1	222.5	178	152.5	23	235	178	152.5	23	251	178	152.5	32
	1.5	222.5	178	152.5	41	235	178	152.5	41	251	178	152.5	46
	2	254	195	181	57	266.7	195	181	57	287	293	272	64
	3	298.5	238	234	100	317.5	238	234	100	317.5	238	234	107
	4	352.5	270	238.5	136	368.5	270	238.5	136	393.2	283	238.5	150
	6	451	330	316.5	238	473	330	316.5	238	-	-	-	-
	8	543	391	370	351	568.5	391	369.5	351	694	499	435	490
	10	625.5	457.5	410.5	780	660.5	457.5	410.5	780	705	574	568.5	1140
	12	730.5	573.5	507.5	980	768.5	573.5	507.5	980	-	-	-	-

ACTUATOR SIZE	ACTUATOR TYPE : 37 DIRECT			ACTUATOR TYPE : 38 REVERSE		
	DIMENSIONS (mm)		UNPACKED WEIGHT (Kg)	DIMENSIONS (mm)		UNPACKED WEIGHT (Kg)
	C	D		C	D	
11	421	330	21	617	330	25
13	516	381	32	782	381	40
15	654	445	55	943	445	75
18	848*	527	82	1360*	527	178
24	870*	686	170	1505*	686	210

* Actuator height varies with spring range/ stroke. Maximum height is indicated. Contact MIL for exact height.

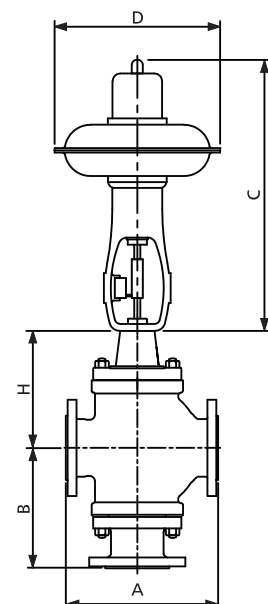



Optional Designs

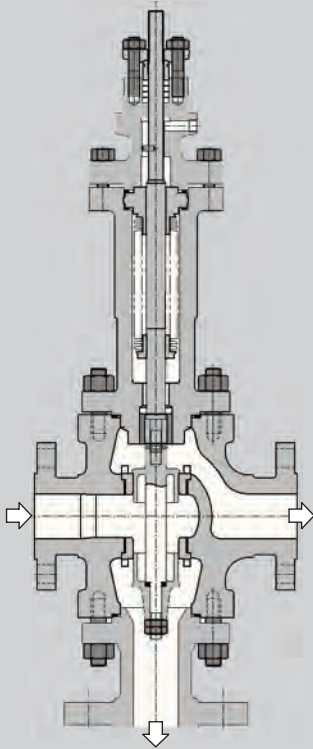

MIL 81000 series 3-way bellow sealed body sub-assembly

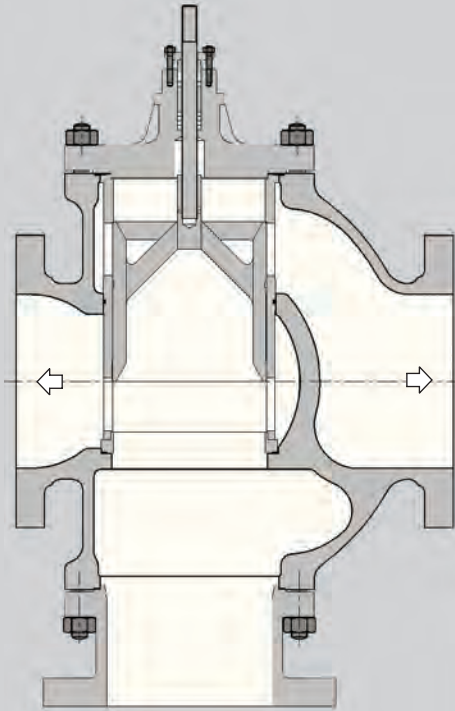

3-way valve body sub-assembly 81500 balanced design

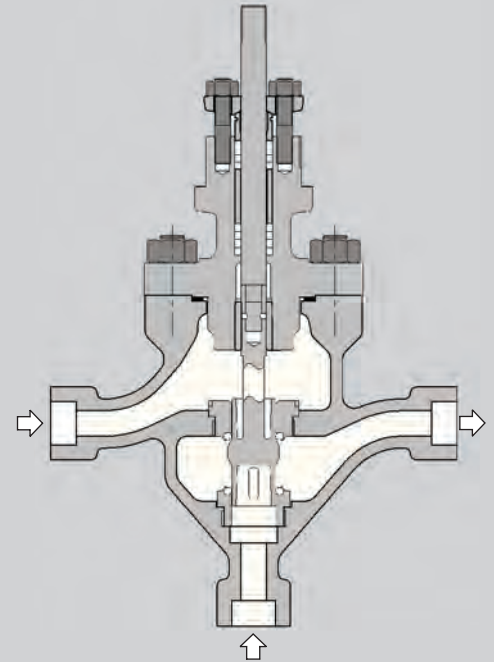

Combining service illustrated (For diverting service, common port 'C' is the inlet)

Sales & Service offices

New Delhi: MIL Controls Ltd., KSB House, A-96, Sector-4, Gautam Budh Nagar, Noida-201 301, India. Tel: +91 (120) 2541091-93, 2541501-03, Fax: +91 (120) 2550567 E-mail: salesnoida.mil@ksb.com **Mumbai:** MIL Controls Ltd., KSB Pumps Ltd., 126, Maker Chamber III, Nariman Point, Mumbai 400 021, India. Tel: +91 (22) 66588787, 66588757-59, 66588761, Fax: +91 (22) 66588788. E-mail: salesmumbai.mil@ksb.com **Kolkata:** MIL Controls Ltd., KSB Pumps Ltd., 2nd Floor, 30 Circus Avenue, Kolkata 700 017, India. Tel: +91 (33) 22809847, 22809848, 22870473, Fax: +91 (33) 22870588, 22809847. E-mail: saleskolkata.mil@ksb.com **Chennai:** MIL Controls Ltd., KSB Pumps Ltd., Guindy House, 2nd Floor, No: 95, Anna Salai, Chennai 600 032, India. Tel: +91 (44) 22352571 -72, 22300629, Fax: +91 (44) 22352749 E-mail: saleschennai.mil@ksb.com **Vadodara:** MIL Controls Ltd., KSB Pumps Ltd., 4-B, Ramakrishna Chambers, Productivity Road, Vadodara 390 005, India. Tel: +91 (265) 2330532, 2333226, Fax: +91 (265) 2350002 E-mail: salesbaroda.mil@ksb.com **Pune:** MIL Controls Ltd., KSB Pumps Ltd., Plot No - 28/21, D-II Block, MIDC, Chinchwad, Pune 411 019, India. Tel: +91 (20) 27409100, Fax: +91 (20) 27470890 E-mail: salespune.mil@ksb.com

Middle East & Asia Pacific

China: KSB Valves (Shanghai) Co.Ltd 29 F. Xing-Yuan Technology Building, 418 Guiping Road, Shanghai, China, Post Code: 200233, Tel: +86-21-6485 1778, Fax: +86-21-6485 9115. **Dubai:** KSB Middle East FZE, P.O.Box: 18315, Jebel Ali, Dubai, U.A.E. Tel: +971-4-883 0455, Fax: +971-4-883 0456 **Indonesia:** PT KSB Indonesia, Jalan Timor Blok D2-1, Kawasan Industri MM 2100 Cibitung, Jawa Barat, Indonesia. Tel: +62 21 89983570, Fax: +62 21 89983571 **Korea:** KSB Korea Ltd, Soo Young Building, 64-1, Hannam-Dong, Yongsan-Ku, Seoul 140-210, Korea. Tel: +82-2-790 4351, Fax: +82-2-790 4350 **Malaysia:** KSB Malaysia Pumps & Valves SDN BHD 29, Jalan PJU 3/47, Sunway Damansara, 47810 Petaling Jaya, Selangor Darul Ehsan, Malaysia., Tel: +60-03-7805 3397, Fax: +60-03-7805 1373 **Singapore:** KSB Singapore (Asia Pacific) PTE Ltd., 4 Woodlands Walk, Singapore 738248. Tel: 6757 7200, Fax: 6482 3005 **Taiwan:** KSB Taiwan Co.Ltd, No: 154-6 Sec 1, Datong Rd, Xizhi Dist, 10635, New Taipei City, Tel: +886-2-2649 2255, Fax: +886-2-2649 8833 **Thailand:** KSB Pumps Co Ltd., Bangkok 10530, Thailand. Tel: +66-2-988 2324, Fax: +66-2-988 2213

MIL Controls Limited
Meladoor, Annamanada, Pin 680 741,
Thrissur Dist., Kerala, India
Tel : +91 (480) 2695700
Fax : + 91 (480) 2890952
Email : sales.mil@ksb.com
Web : www.milcontrols.com



MIL

A KSB Company • **KSB** 